

# FACT optical distribution frame (ODF) platform

# FACT optical distribution frame (ODF) platform

---

## MEETING THE CHALLENGES OF TOMORROW'S HIGH FIBER-COUNT NETWORKS

In central offices, headends and data centers, demand for bandwidth is growing exponentially. The need to install, access, reconfigure and reroute connections is constant. As the physical layer evolves, termination, splicing, patching and storage requirements surpass the capabilities of standard rack and panel offerings.

Network managers need a better solution, one that supports rapid deployment, plug-and-play connectivity and high density—all while maximizing the usable density and long-term value of the fiber network. The FACT® optical distribution frame (ODF) system from CommScope is a compact, **fully front-accessible** solution that maximizes usable density and supports the continued growth of your fiber infrastructure.

As a modular solution, the FACT optical distribution frame (ODF) system is fully customizable: configure and incorporate universal adaptor packs, cabled modules, MPO modules and value-added modules within a single frame or a lineup of multiple frames. Incorporating CommScope's popular NG4access® optical distribution frame modules, FACT provides a flexible, reliable and cost-effective solution to your evolving network needs.

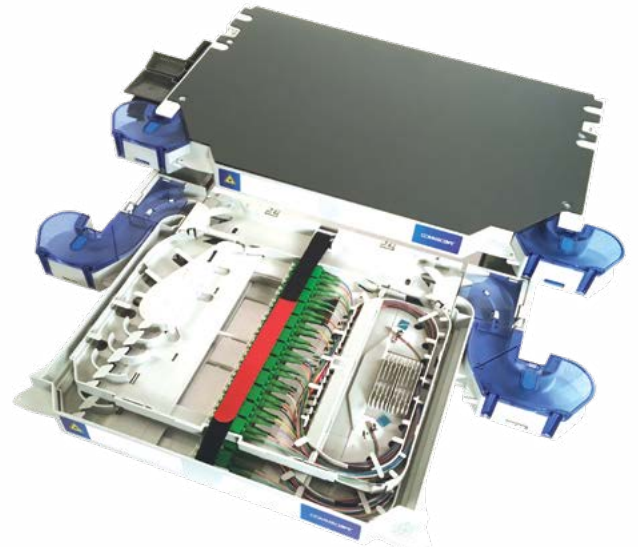

Figure 1: FACT splice-patch chassis

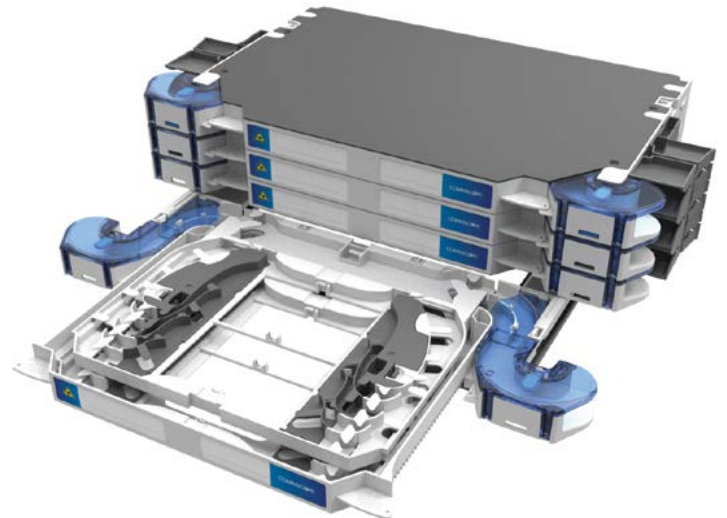

Figure 2: Four element universal FACT NG4 chassis

# Powerful benefits

---

The forward-looking design of the FACT optical distribution frame system addresses the most pressing needs for your ever-changing fiber network: reliable performance, seamless transition to future applications and a higher overall return on investment.

## SCALABLE, MANAGEABLE DENSITY

With a compact and lightweight frame, high-density plug-and-play elements, and full-frontal access, the FACT optical distribution frame system scales smoothly and logically. The innovative snap-on design requires no tools—reducing installation time by as much as 50 percent. System maintenance is enhanced as well. All fibers remain identifiable and accessible, allowing technicians to:

- Support up to 2,688 individually accessible LC fiber connections in a fully front-accessible frame
- Locate and trace individual fibers along easy-to-follow cable routing paths
- Complete moves, adds and changes quickly and accurately
- Minimize installation time to live connections through ample room to work
- Reduce inventory and increase component availability with a single fixed patch cord length for all in-rack and panel connections
- Manage interconnects as well as cross-connects
- Perform advanced splicing, management and storage from a single point

## LONG-TERM AGILITY

The FACT ODF system is designed to flex and grow as the fiber needs of your network continue to evolve. Its modular design and simplified installation and management enable long-term agility to meet tomorrow's challenges.

- Supports the any-to-any configurations of today's leaf-and-spine architecture
- Enables on-the-fly addition of splitters, wavelength division multiplexers (WDMs), taps and connectivity modules
- Supports a grow-as-needed approach that avoids overprovisioning and preserves precious capital

## LOWER TOTAL COST OF OWNERSHIP

Agility and optimized cable management lower total cost of ownership through maximized usable density, more effective capital deployment and improved operational efficiency:

- Maximize fiber density and manageability
- Deploy standard cable configurations to reduce installation and inventory costs
- Decrease troubleshooting time and need to install or reroute fibers
- Reduce mean time to repair and downtime costs
- Accelerate time to market and time to revenue
- Enhance return on investment (ROI)

CommScope's  
FACT solution

Minimizes  
installation time

Simplifies  
installation and  
management enable  
long-term agility to  
meet tomorrow's  
challenges

Lowers total cost of  
ownership through  
maximized usable  
density

# Modular design

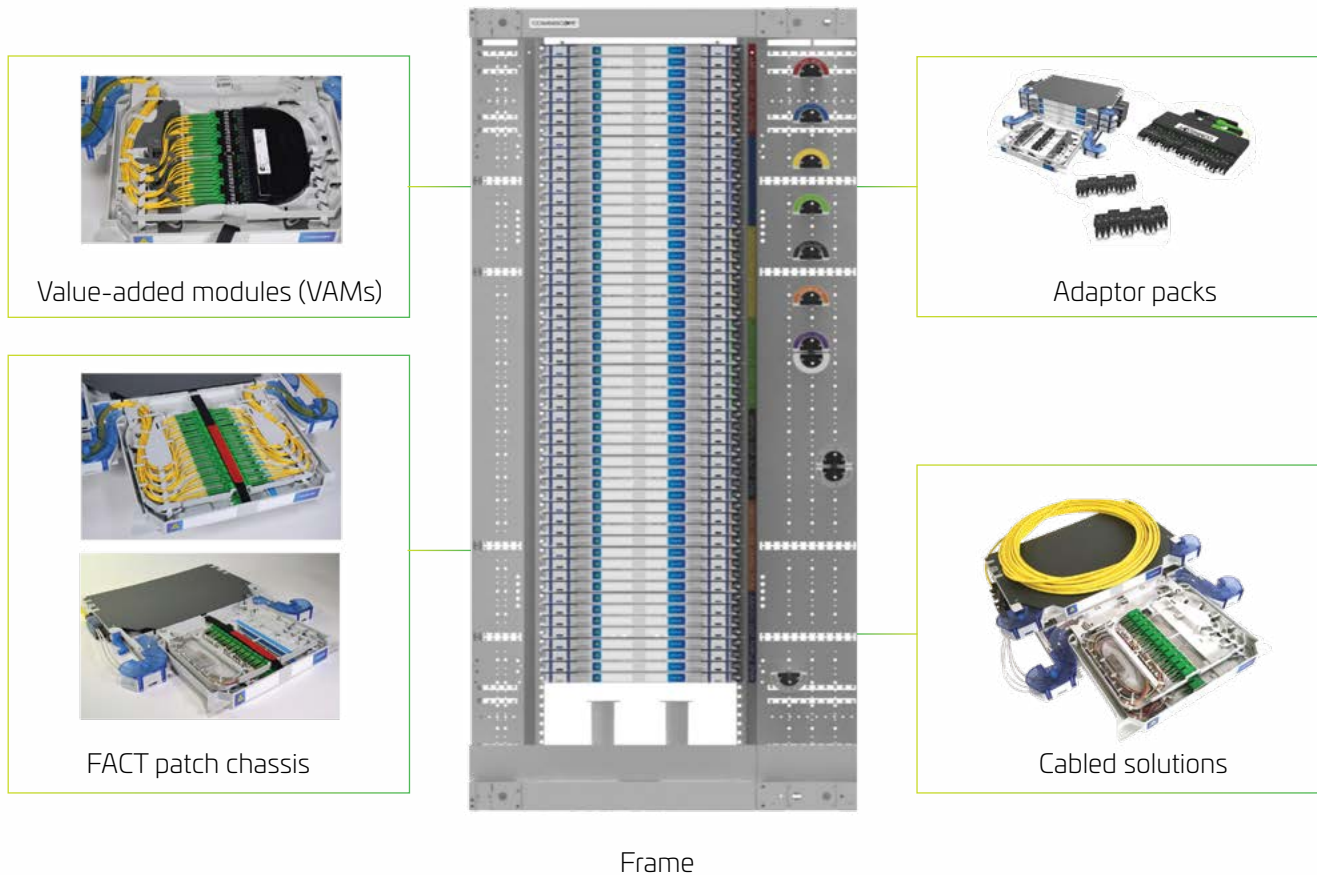

Figure 3: Full frame breakout with horizontal central building blocks

## FRAME

The FACT optical distribution frame system is designed for use with CommScope's all-purpose FIST-GR3 frames. Based on the ETSI standard (600 millimeters wide), the frame provides intuitive fiber management and handling, supporting up to 2,688 LC connections in a single frame. Side ducts (150 mm and/or 300 mm wide) are included in the frame kits. Optional fiber over-length storage bays support slack management, and a range of frame accessories—such as top and side panels, doors, cable attachment plates and cable clamps—are available as well.

## ELEMENTS AND CHASSIS

FACT elements—the basic building blocks of the system—may be deployed individually as a single-element chassis or grouped with other elements for higher density solutions. Each element measures 30.95 mm tall, 30 percent less than the standard HU (44.45 mm). Each element supports two hinged trays that provide full front access to both sides of all connections and clear visibility of all ports. Four chassis types—patch-only, patch-splice, pre-cabled and NG4—enable customization of the FACT optical distribution frame to support virtually any application.

## ADAPTOR PACKS

FACT adaptor packs are available in LC 12-pack, SC six-pack and MPO four-pack configurations, and are compatible with singlemode and multimode, angled and ultra-polished connectors. All adaptor packs are compatible with the universal FACT NG4 chassis. Two adaptor packs snap into a single access tray. Staggered adaptor ports improve access for quick and easier connector insertion and removal, and help to clearly identify individual adaptor ports.

## MPO MODULES

FACT MPO modules are used with the universal FACT NG4 chassis. The front of the MPO module offers the same familiar interface as standard LC and SC adaptor modules. The rear of the module features a low-loss MPO adaptor that allows direct connection to preterminated MPO trunk cables—so you can provision up to 24 circuits at a time.

## VALUE-ADDED MODULES

NG4access value-added modules enhance optical transport systems by providing flexible, easy-to-incorporate optical components that increase fiber capacity, enhance system monitoring, or distribute signals to multiple subscribers. Value-added modules are used with the universal FACT NG4 chassis.

## ACCESSORIES (SOLD SEPARATELY)

Accessories for the FACT chassis include cable termination components for all cables, sizes and types, plus doors and panels for the frame.

## SPLICE-ONLY CHASSIS

The FACT splice-only chassis is a multipurpose splice shelf featuring single-circuit and single-element fiber management.

## PATCH CORDS

The FACT optical distribution frame system solution works best when using fixed patch cord lengths within the same frame, or between adjacent frames. Patch cords with a diameter of 1.8 mm or less enable an effective usable density of 2,688 connections per frame.

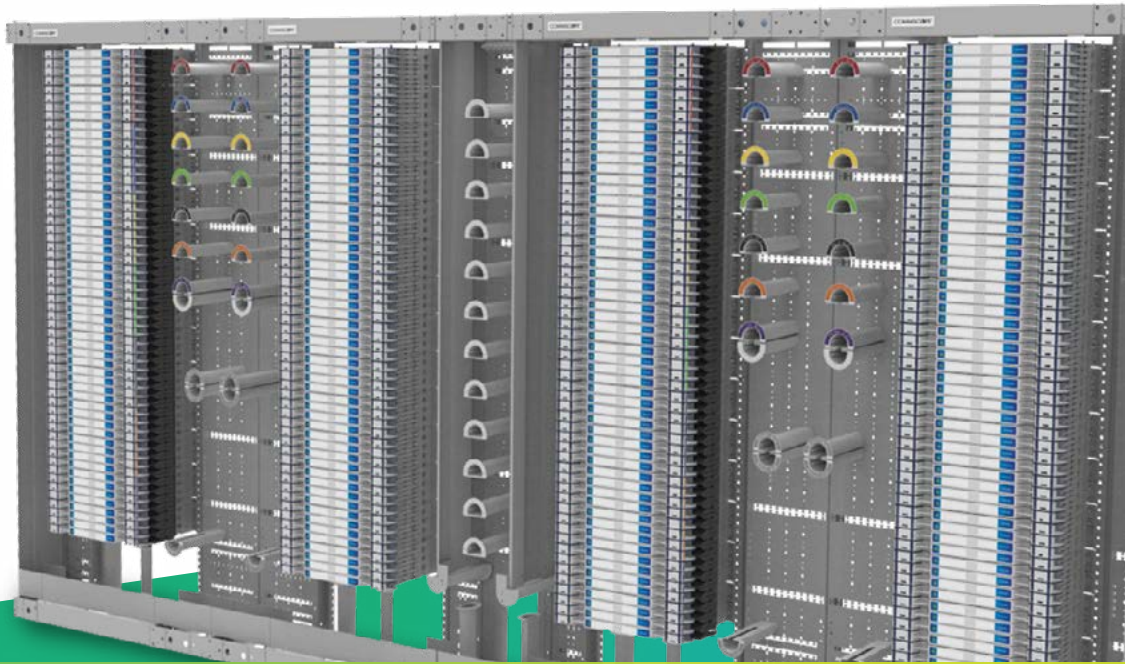

Optimal access for quick and easy  
connector insertion and removal

# FACT optical distribution frame (ODF) platform at a glance

APPLICATION	
General:	Medium to large front access fiber applications
Location:	Main distribution area
Function:	Cross-connect or interconnect
DIMENSIONS	
Width:	1,050 mm or 1,200 mm (41 in. or 47 in.)
Depth:	300 mm (12 in.)
INSTALLATION PRACTICES	
Patching direction:	In tray
Max frames per lineup at max density (recommended):	4 (without FiberGuide) - equals 10752 single LC connections 16 (with FiberGuide) - equals 43008 single LC connections
Recommended patch cord OD:	- SC: <= 2 mm - LC: <= 1.8 mm
Recommended patch cord length within the same frame or within a side-by-side twin frame:	5 meters
On-frame splicing:	Yes with density reduction
Jumper slack storage location:	On frame
Interconnect:	Excellent
Cross-connect:	Excellent
CAPACITY	
Connections/frame:	SC/LC 1344/2688 MPO 12 fiber 10752 MPO 24 fiber 21504
Splices/frame:	- Splice-Patch chassis: 2688 splices - Splice chassis: 4032 splices (with SMOUV protector)
Connection density for frame width 1200mm:	SC 3733/343 LC 7466/686 MPO 29866/2745
Elements per frame:	56
Value-added module (VAM) capacity:	Yes (FACT-NG4 chassis only, two per FACT element)
NG4 adaptor packs capacity:	Yes (FACT-NG4 chassis only, four per FACT element)
NG4 MPO modules capacity:	Yes (FACT-NG4 chassis only, two per FACT element)
NG4 cabled modules capacity:	Yes (FACT-NG4 chassis only, two per FACT element)
SPECIFICATIONS	
Compliance:	IEC 6300-2
Seismic rating:	Zone 2
Supported fiber types:	20 mm bend radius

# The Frame

---

CommScope's all-purpose, easy-to-use FIST™-GR3 frame is based on the standards set by the European Telecommunications Standards Institute and is designed to meet today's high-density network needs. The front access frame provides full hand access to both sides of all connections, for a more compact effective footprint. The frame ships in a lightweight, compact kit for easy handling, storage and transport and is easy to install on site—even by a single operator in less than 30 minutes.

The frame offers many mounting options and configurations. The twin frame can be mounted on the floor or against a wall, side-to-side or back-to-back. For larger lineups, multiple twin frames can be deployed side-by-side. FACT back plates (sold separately) for the FIST-GR3 frame are available to accommodate FACT modules, as well as four and 28 FACT elements. Each frame houses up to 56 FACT elements and as many as 2,688 single LC connections. Engineered bend control during routing maintains superior optical performance and easy access to cables, pigtailed and jumpers during installation, operation, maintenance and upgrades.

Cable attachment plates are incorporated into the side ducts, and a range of accessories such as doors, top and side panels, over-length storage bays, extended base ducts and extra cable attachment plates are available as well.



Figure 4: Single frame, recommended patch cord length for all cross-connects is 5 meters (20 ft.).



Figure 5: Twin frame deployed side-by-side.

Recommended patch cord length for all cross-connects is 5 meters (20 ft) inside the twin frame.



Figure 6: Four-frame block, deployed side-by-side, with side panels and with storage bay in between the two twin frames.

Recommended patch cord length for the cross-connects between the two twin frames is 10 meters (40 ft).

## FRAME ORDERING INFORMATION

Description	Dimensions: H x W x D	Max. termination capacity	Catalog number	Catalog description
Frame with 2 x 150 mm side ducts	2,200 mm x 900 mm x 300 mm (87 in. x 35 in. x 12 in.)	2,688 LC or 1,344 SC connections per frame	CS6171-000	FIST-GR3-R-150/150-2-22
Frame with 150 mm and 300 mm side duct	2,200 mm x 1,050 mm x 300 mm (87 in. x 41 in. x 12 in.)	2,688 LC or 1,344 SC connections per frame	CS6177-000	FIST-GR3-R-150/300-2-22
Frame with 2 x 300 mm side ducts	2,200 mm x 1,200 mm x 300 mm (87 in. x 47 in. x 12 in.)	2,688 LC or 1,344 SC connections per frame	CS6174-000	FIST-GR3-R-300/300-2-22

All frames include:

- Two side ducts with integrated ETSI mounting profiles: manage and house cables, pigtails, patch cords
- Base duct measures 8HU
- Loose drums (15x)
- Cable attachment plates and drum plates integrated into management panel
- Wall and back-to-back connection kits
- Earthing kit
- Adjustable feet
- Intuitive installation instructions and footprint template
- Rack-painted (powder-coated) light gray (RAL-7035)
- Label kit for color identification of the spools
- All hardware and fasteners

## FRAME ACCESSORIES ORDERING INFORMATION

Description	Dimensions	Catalog number	Catalog description
FACT back plate, mounts four FACT elements in GR3 frame	120 mm x 531.5 mm (H x W) (4.8 in. x 20.9 in.)	760239955	FACT-ACCBPL4E
FACT back plate, mounts 28 FACT elements in GR3 frame (recommended)	873 mm x 531.5 mm (H x W) (34.4 in. x 20.9 in.)	760239956	FACT-ACCBPL28E
Door for 150 mm side duct	2,200 mm x 150 mm (H x W) (87 in. x 6 in.)	CZ9821-000	FIST-GR3-D-150-22-2
Door for 300 mm side duct	2,200 mm x 300 mm (H x W) (87 in. x 12 in.)	CZ9825-000	FIST-GR3-D-300-22-2
Door for 600 mm side duct, w/lock	2,200 mm x 600 mm (H x W) (87 in. x 24 in.)	CZ9827-000	FIST-GR3-D-600-22-2
Top cover for 150 mm side duct	150 mm x 300 mm (W x D) (6 in. x 12 in.)	CZ9047-000	FIST-GR3-T-150
Top cover for 300 mm side duct	300 mm x 300 mm (W x D) (12 in. x 12 in.)	CW5887-000	FIST-GR3-T-300
Top cover for 600 mm central section	600 mm x 300 mm (W x D) (24 in. x 12 in.)	CK8631-000	FIST-GR3-T-600
Set (of two) side or back panels	2,200 mm x 300 mm (H x W) (87 in. x 12 in.)	CS9084-000	FIST-GR3-P-300-22
Storage bay (includes a fiber passage for back-to-back configuration)	2,200 mm x 300 mm x 300 mm (H x W x D) (87 in. x 12 in. x 12 in.)	CV7092-000	FIST-GR3-SB-300-22-2
Extended base duct for 150 mm side duct; increases patch cord capacity at bottom of frame; incoming feeder cable must come from top of frame	215 mm (D) (8.5 in.)	EF7794-000	FIST-GR3-BD-150/215
Extended base duct for 300 mm side duct; increases patch cord capacity at bottom of frame; incoming feeder cable must come from top of frame	215 mm (D) (8.5 in.)	EF7793-000	FIST-GR3-BD-300/215
Set (of two) side-by-side brackets	n/a	CC9465-000	FIST-GR3-ST5
Kit to route jumpers from front to back of rack; required when using extended base duct	215 mm (D) (8.5 in.)	EF8196-000	FIST-GR3-BD-BTB-600/215
Containment brackets—maintain patch cords in side duct	n/a	315826-000	FIST-GR2-PCBR-10



# FACT chassis types

The building blocks of the FACT optical distribution frame system are the FACT chassis. FACT chassis can be deployed individually as a single-element chassis, or up to six similar elements can be combined into high fiber-count FACT chassis.

The single-element FACT chassis measures 30.95 mm (1.22 in.) tall, 30 percent less than the standard HU/1RU (44.45 mm/1.75 in.). Each FACT element features two hinged trays, providing full front access to both sides of all connections and clear visibility of all ports. There are four FACT chassis types.



Figure 7: Three element patch-only chassis

## PATCH-ONLY CHASSIS

The FACT patch-only chassis supports cross-connect and interconnect applications and is available with SC and LC adaptors. The FACT patch-only chassis accommodates 24 SC connections or 48 single LC connections per element.

## PATCH-ONLY CHASSIS: ORDERING INFORMATION

FACT - <sup>1</sup>XX PAT <sup>2</sup>XX

### Element count

1	1E	One element
	2E	Two elements
	3E	Three elements
	4E	Four elements
	5E	Five elements
	6E	Six elements

### Adaptor types, Port count

2	S1	SC UPC, 24 ports per element
	S2	SC APC, 24 ports per element
	S4	SC OM4, 24 ports per element
	L1	LC UPC, 48 single LC ports per element
	L2	LC APC, 48 single LC ports per element
	L4	LC OM4, 48 single LC ports per element

## SPLICE-PATCH CHASSIS

Preterminated with pigtails, the FACT splice-patch chassis enables splicing of OSP or ISP cables directly on the frame with no loss of density. Available with SC or LC preterminated connections, the high-density chassis accommodates 24 SC or 48 single LC connections per FACT element and uses the EIA/TIA 598 color-coding standard.

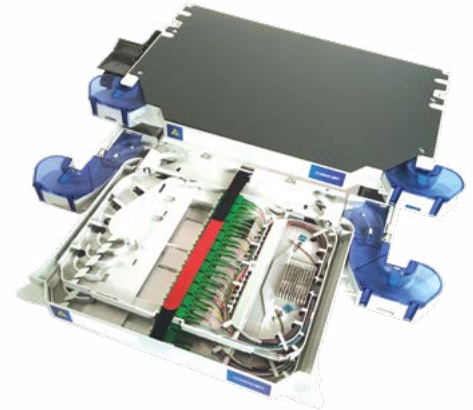

Figure 8: Two-element splice-patch chassis with left-side patching

## SPLICE-PATCH CHASSIS ORDERING INFORMATION

FACT- 1 XX 2 X H P 3 XX 4 X

**Element count**

1	1E	One element
	2E	Two elements
	3E	Three elements
	4E	Four elements
	5E	Five elements
	6E	Six elements

**Patch cord side**

2	L	Left-hand patch
	R	Right-hand patch

**Splice holder/protector**

4	S	SMOUV
	A	ANT

**Adaptor/connector types, Port count**

3	S1	SC UPC, C-grade, 24 ports per element
	S2	SC APC 8°, C-grade, 24 ports per element
	SF	SC UPC, B-grade, 24 ports per element
	SG	SC APC 8°, B-grade, 24 ports per element
	S4	SC OM4, 24 ports per element
	L1	LC UPC, C-grade, 48 single LC ports per element
	L2	LC APC, C-grade, 48 single LC ports per element
	LF	LC UPC, B-grade, 48 single LC ports per element
	LG	LC APC, B-grade, 48 single LC ports per element
	L4	LC OM4, 48 single LC ports per element

**COLOR CODING**

Fiber 1	Blue
Fiber 2	Orange
Fiber 3	Green
Fiber 4	Brown
Fiber 5	Grey
Fiber 6	White
Fiber 7	Red
Fiber 8	Black
Fiber 9	Yellow
Fiber 10	Purple
Fiber 11	Pink
Fiber 12	Turquoise

Note: All fibered standard FACT products use EIA/TIA 598 color coding

## PRE-CABLED CHASSIS

The FACT pre-cabled chassis is supplied with connectorized cables from 48 fibers to 144 fibers, and a stub on the far end. It is available for indoor cable in lengths up to 350 meters. The pre-cabled chassis accommodates 24 SC or 48 single LC connections per FACT element. All pre-cabled FACT chassis use EIA/TIA 598 color-coding standard.

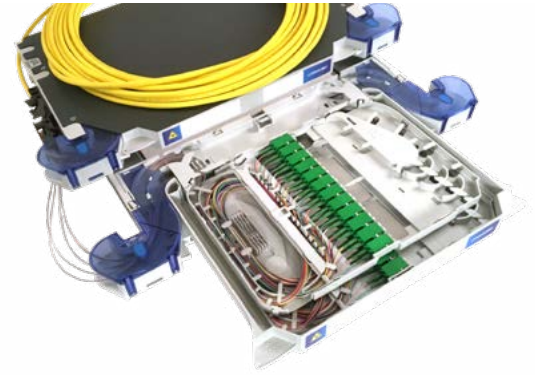
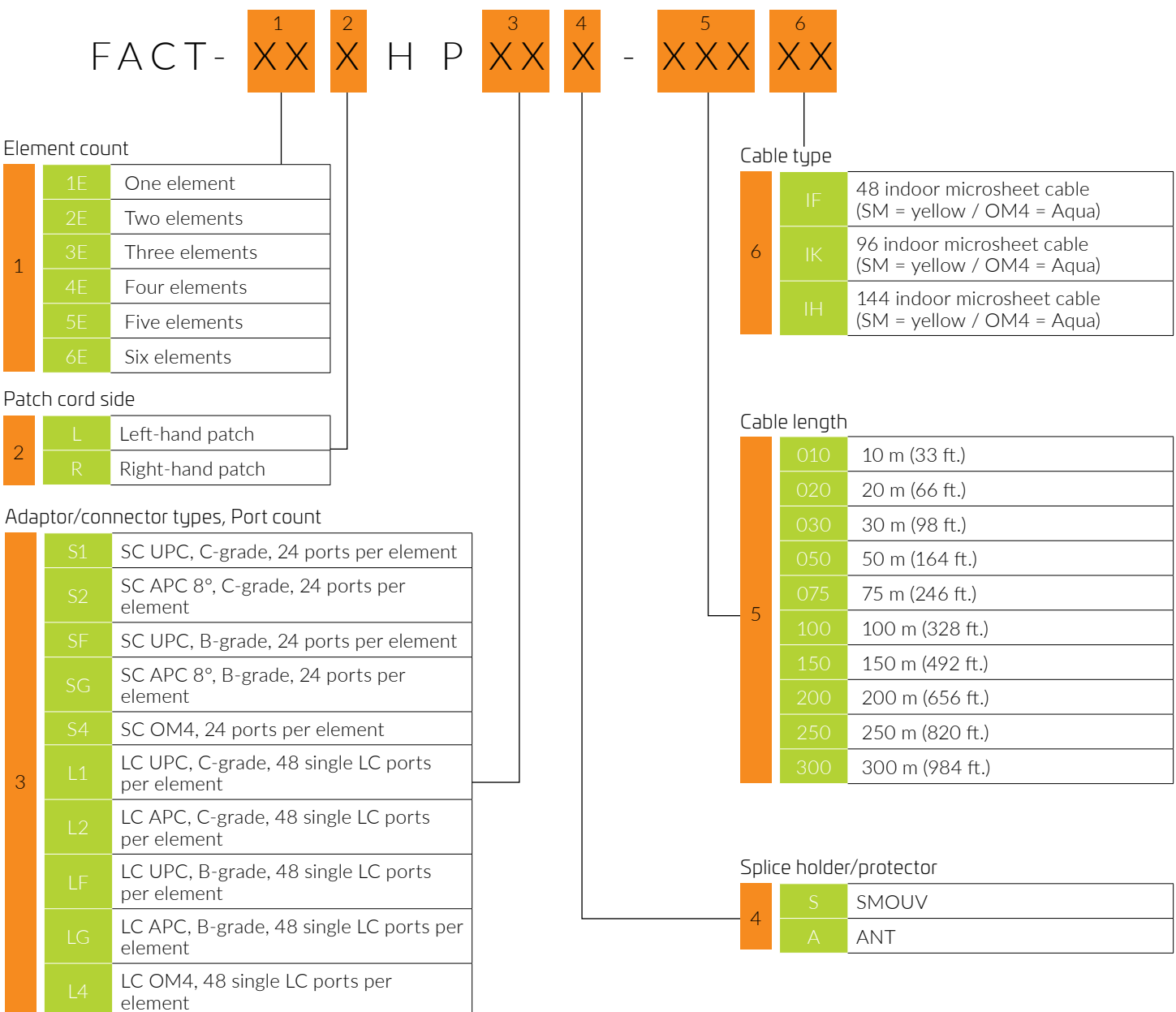

Figure 9: Two-element pre-cabled chassis with 96f. indoor microsheet cable and right-side patching

## PRE-CABLED CHASSIS ORDERING INFORMATION



## FACT NG4 CHASSIS

The universal FACT NG4 chassis supports NG4access connectivity packs and modules that snap into the FACT NG4 chassis. In addition to SC, LC and MPO adaptor packs, it also accommodates MPO-to-LC or MPO-to-SC modules, cabled modules and value-added modules (VAMs).

The FACT NG4 element includes two trays; each element can accommodate:

- Four LC or SC adaptor packs
- Two MPO modules
- Two 24-fiber LC cabled modules
- Two 12-fiber SC cabled modules
- Two value-added modules

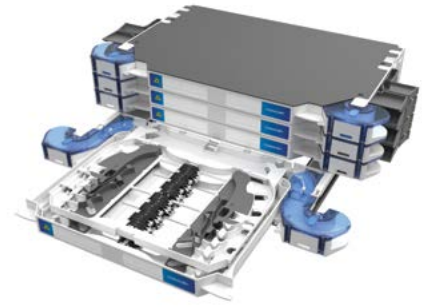

Figure 10: Four-element FACT NG4 chassis with LC adaptor pack



Figure 11: Single-element FACT NG4 chassis with right-exit MPO module

## FACT NG4 CHASSIS: ORDERING INFORMATION

FACT- <sup>1</sup>XX NG4

Element count

1	1E	One element
	2E	Two elements
	3E	Three elements
	4E	Four elements
	5E	Five elements
	6E	Six elements

# Universal adaptor packs

FACT universal adaptor packs are designed to accept singlemode and multimode connections with ultra-polished or angle-polished connectors. A staggered adaptor design allows technicians to easily identify and access individual connections without disturbing adjacent circuits and eliminates the need for insertion or extraction tools.

Each FACT element supports up to four universal adaptor packs; two LC12, SC6 or MPO4 adaptor packs can be installed per tray.

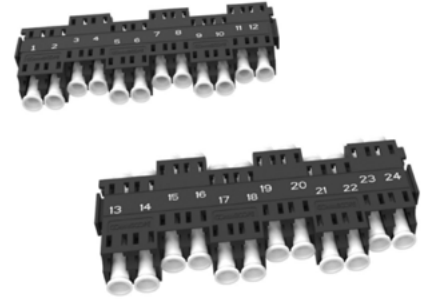

Figure 12: LC12 universal adapter packs

UNIVERSAL ADAPTOR PACKS ORDERING INFORMATION			
Description	Capacity	Dimensions (H x W x D)	Catalog number
Snap-in LC12 universal adaptor pack (two packs w/labels)	24 single LC connections	84 mm x 33 mm x 10 mm (3.3 in. x 1.3 in. x 0.4 in.)	NG4-APLC120000
Snap-in SC6 universal adaptor pack (two packs w/labels)	12 SC connections		NG4-APSC060000
Snap-in MPO adaptor four-pack, Method A (key up/down) polarity (two packs w/labels)	8 MPO connections		NG4-MP040000

# MPO modules

FACT MPO modules enable technicians to route and install higher fiber counts faster and more easily, while simplifying inventory and ordering. The front interface for LC and SC connectors is identical to the cabled module, while the rear integrates a low-loss MPO adaptor—enabling installers to quickly connect MPO trunk cables for rapid installation and turn-up. This module also supports direct connection to electronics, fiber tie cables or top-of-rack systems such as CommScope’s Rapid panels or MFPS panel. The MPO module snaps into place within the FACT NG4 tray, and each FACT NG4 element supports up to two MPO modules. Standard routing is method A; method B enhanced is available on request.

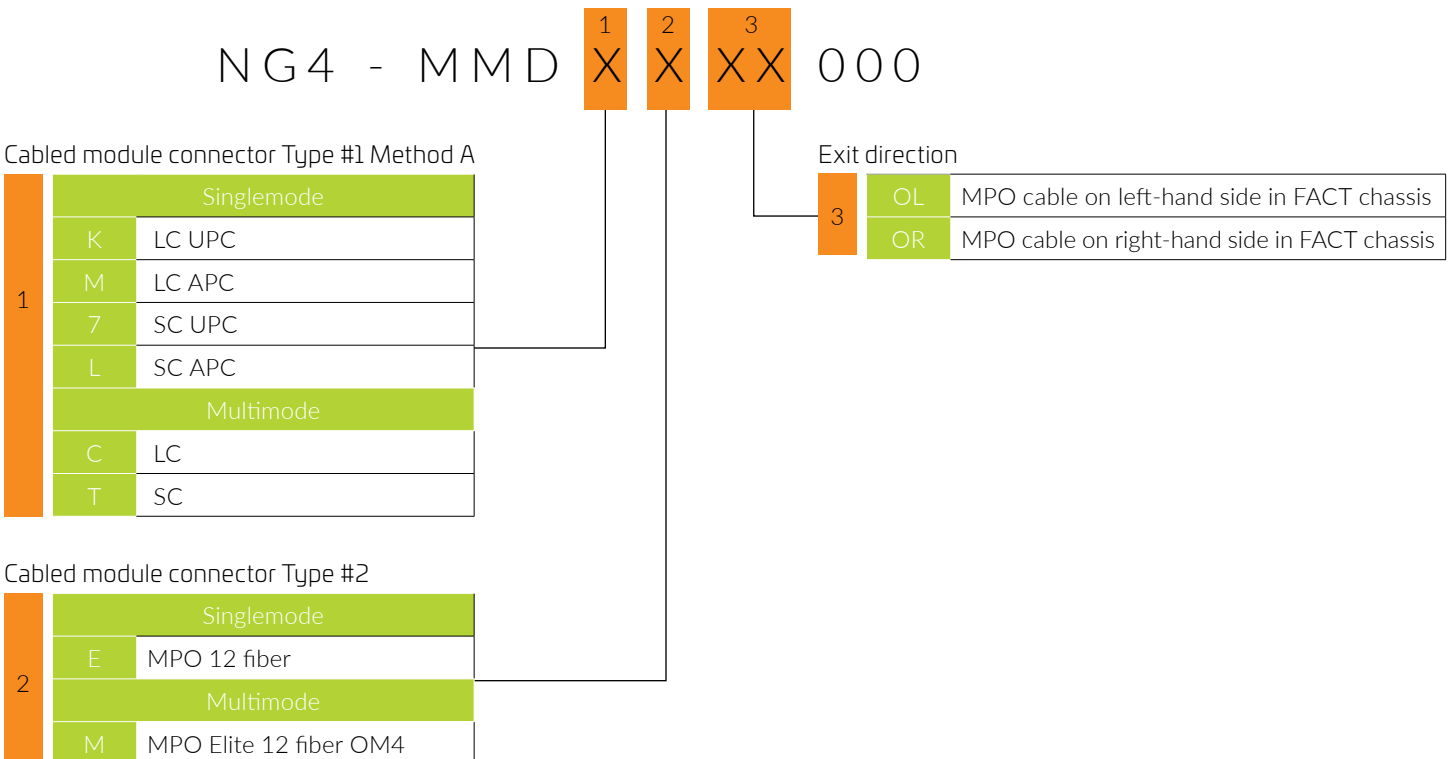

Figure 13: Right-exit MPO module with LC adaptors



Figure 14: Right-exit MPO module with SC adaptor

## MPO MODULES: ORDERING INFORMATION



# Value-added modules (VAMs)

## VALUE-ADDED MODULE SPLITTERS

Value-added module splitters are used to split or combine optical signal power from one fiber to multiple fibers. Additionally, NG4access VAM splitters support signal distribution in passive optical networks.

## VALUE-ADDED MODULE SPLITTERS ORDERING INFORMATION

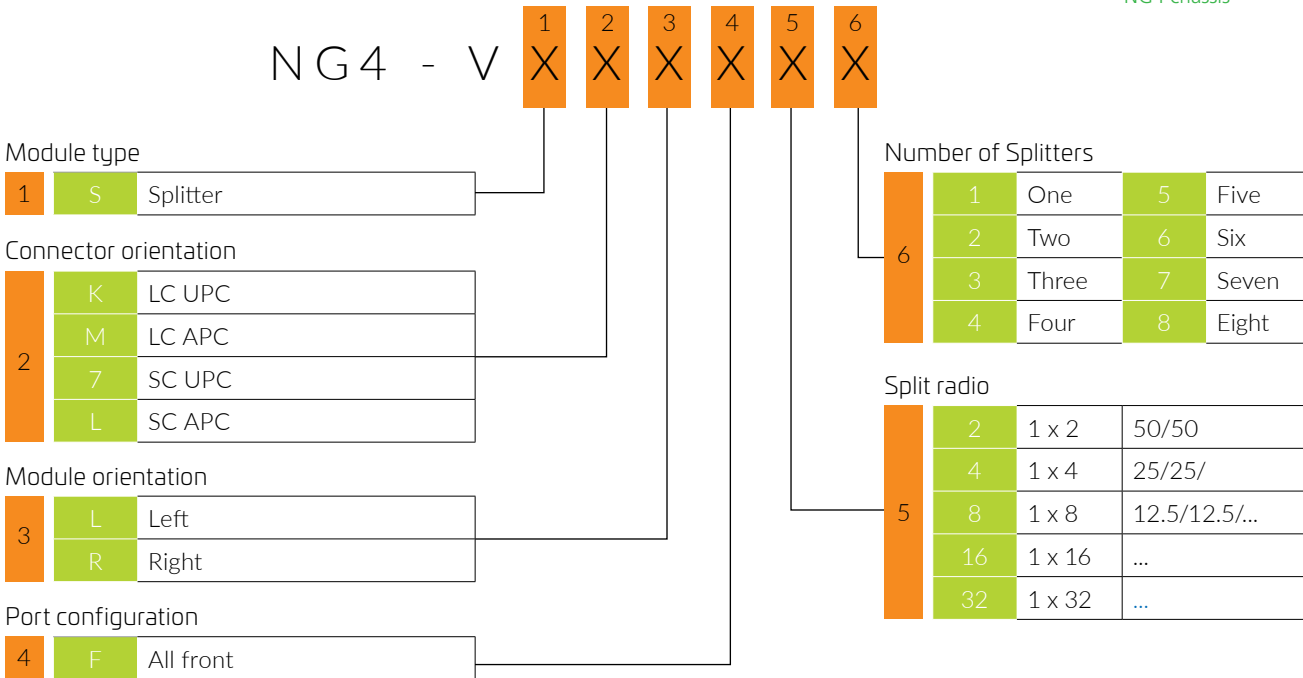

Figure 15: Value-added module shown loaded into a FACT NG4 chassis

## MONITOR VALUE-ADDED MODULES

The FACT portfolio also includes value-added modules (VAMs), which enable monitoring and testing of singlemode and multimode optical signals. These non-intrusive monitor VAMs provide a wide range of tap ratios to meet specific application requirements. Technicians can easily monitor bi-directional traffic at a single point to identify signal degradation and locate failures more quickly. Multimode monitor VAMs operate at data rates of 10 Gbps and below.



Figure 16: CWDM, 8 channels + T, with SC APC connectors

### SINGLEMODE MONITOR VAMS ORDERING INFORMATION

Description	Connector	Orientation	MID
Two circuits 90/10 tap ratio	SC UPC	Left	NG4-VM7LF2A
Two circuits 90/10 tap ratio	SC UPC	Right	NG4-VM7RF2A
Four circuits 60/40 tap ratio	LC UPC	Left	NG4-VMKLF4J
Four circuits 60/40 tap ratio	LC UPC	Right	NG4-VMKRF4J
Four circuits 50/50 tap ratio	LC UPC	Left	NG4-VMKLF4C
Four circuits 50/50 tap ratio	LC UPC	Right	NG4-VMKRF4C

### MULTIMODE MONITOR VAMS ORDERING INFORMATION

Description	Connector	Orientation	MID
Four circuits 70/30 tap ratio	LC multimode	Left	NG4-VMKNLF4H010GM
Four circuits 70/30 tap ratio	LC multimode	Right	NG4-VMKNRF4H010GM
Four circuits 60/40 tap ratio	LC multimode	Left	NG4-VMKNLF4J010GM
Four circuits 60/40 tap ratio	LC multimode	Right	NG4-VMKNRF4J010GM
Four circuits 50/50 tap ratio	LC multimode	Left	NG4-VMKNLF4C010GM
Four circuits 50/50 tap ratio	LC multimode	Right	NG4-VMKNRF4C010GM

## VAMS FOR COARSE/DENSE WAVELENGTH DIVISION MULTIPLEXING

The FACT portfolio also includes value-added modules for coarse wavelength division multiplexing (CWDM) and dense wavelength division multiplexing (DWDM) combine or separate signals of different wavelengths. CWDM VAMs provide a wide range of wavelength combinations—from four to eight channels—while DWDM VAMs are typically used to combine eight to 40 channels. Both types of value-added modules support up to 12 SC or 24 LC front-facing connectors. Available test ports enable rapid signal turn-up and simplified test access. For details on available configurations please contact your account manager or field application engineer.



Figure 17: Element FACT NG4 chassis with VAM and SC connectors



# Accessories

## CABLE TERMINATION KITS

Cable termination kits enable quick and easy termination of small, flexible cables on the FACT chassis, as well as larger and stiffer cables in the frame side duct. They support most cable sizes and types.

FACT cable termination units (CTUs) are specifically designed for termination of small flexible cables directly onto the FACT chassis. This allows the installer to preterminate a cable on the CTU outside the frame.

FIST-GR3 cable attachment plates are used for terminating and securing larger or stiffer cables in the frame side duct.

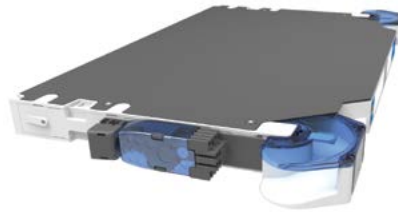

Figure 18: Cable termination unit (CTU) on chassis



Figure 19: Installed cable termination units (CTUs) on FACT chassis

### CABLE TERMINATION UNIT (CTU) ORDERING INFORMATION

Cable type—termination capacity	Diameter range	Catalog number	Catalog description
CTU for one cable with maximum diameter of 15 mm or one flex tube of 12-16 mm (with transparent cover)	Cable: 9 mm to 15 mm Flex tube: 1 x ID12 mm, or 2 x ID 10 mm	760239897	FACT-ACCCTULLT
CTU for one cable with maximum diameter of 15 mm or one flex tube of 12-16 mm	Cable: 9 mm to 15 mm Flex tube: 1 x ID12 mm, or 2 x ID 10 mm	760239898	FACT-ACCCTUMLT
One IFC-cable	15 mm (max.)	760239899	FACT-ACCCTUMIFC
Trumpet, KTUs for 24 pigtails	1.8 mm (min.) 2.4 mm (max.)	760239900	FACT-ACCCTUMP24
One or two IFC-cables	One cable: 8.5 mm (max.) Two cables: 6 mm (max.)	760239951	FACT-ACCCTUSIFC
One fiber cable or one flex tube 6/10 mm	Cable: 8.5 mm (fiber cable max.) Flex tube: 1 x 10 mm	760239952	FACT-ACCCTUSLT

### CABLE ATTACHMENT PLATE ORDERING INFORMATION

Description	Catalog number	Catalog description
L-cable attachment plate—supports up to 10 IFC or breakout cables; mounts perpendicularly in side duct	EG5792-000	FIST-GR3-BOIC-LPL
Back plate for 300 mm duct—accommodates up to nine FIST-GR2-BOIC-LPL; mounts flat on 300 mm side duct	D35100-000	FIST-GR2-BOIC-BPL
Internal extension cable attachment plate for 150 mm side duct	CW8226-000	FIST-GR3-CAP-150-INT
Internal extension cable attachment plate for 300 mm side duct	EG0850-000	FIST-GR3-CAP-300-INT
Containment brackets; manage patch cords in side duct	315826-000	FIST-GR2-PCBR-10

# FACT Splice chassis

The FACT splice chassis is a multipurpose splice shelf featuring up to 96 ANT splices or 72 SMOUV splices per FACT element. In combination with the FACT-ACCCTU accessories, the FACT splice chassis supports multiple splice applications, including:

- Outdoor-to-indoor loose-tube cable
- Loose-tube cable to pigtails (single aramid yarn termination)
- Loose-tube cable to breakout or intra-facility (IFC) cable
- Pigtail to pigtail (single aramid yarn termination)



Figure 20: Four-element splice chassis, six trays per element, 12 SMOUVs per tray

## FACT SPLICE CHASSIS ORDERING INFORMATION

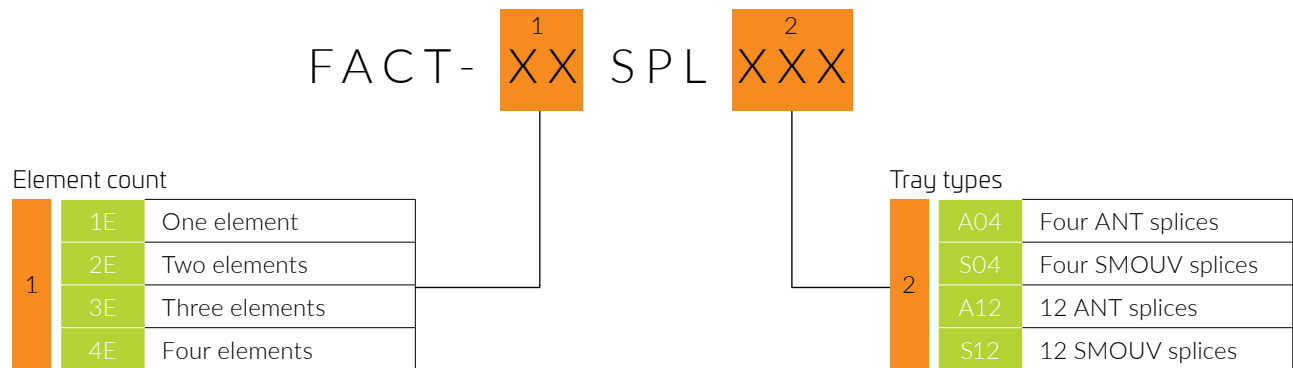

NUMBER OF TRAYS PER FACT-CHASSIS				
	A04	S04	A12	S12
1E	12	12	8	6
2E	24	24	16	12
3E	36	36	24	18
4E	48	48	32	24

# Rely on CommScope

---

The transition to centralized radio access networks (C-RAN), the increasing use of virtual fiber in support of small cells, the need to migrate to higher lane speeds—trends and technologies like these are reshaping today's central office and driving demand for fiber to levels unimagined just a few years ago. As fiber counts grow, fiber management grows more demanding.

With CommScope and our FACT optical distribution frame (ODF) system, you're set. One modular platform—one innovative and experienced partner to help you evolve and grow your network, unimpeded and with the confidence you need. For more information on the FACT ODF, contact CommScope.

CommScope doesn't just participate in trends—we pioneer them. For over 40 years, we have partnered with our customers to identify, design and build specialized solutions for data centers, headends and central offices. With a history of results and a focus on tomorrow, we are simultaneously readying you for the future.



CommScope (NASDAQ: COMM) helps design, build and manage wired and wireless networks around the world. As a communications infrastructure leader, we shape the always-on networks of tomorrow.

For more than 40 years, our global team of greater than 20,000 employees, innovators and technologists has empowered customers in all regions of the world to anticipate what's next and push the boundaries of what's possible. Discover more at [commscope.com](https://www.commscope.com)

**COMMSCOPE®**

---

[commscope.com](https://www.commscope.com)

Visit our website or contact your local CommScope representative for more information.

© 2018 CommScope, Inc. All rights reserved.

Unless otherwise noted, all trademarks identified by ® or ™ are registered trademarks, respectively, of CommScope, Inc. This document is for planning purposes only and is not intended to modify or supplement any specifications or warranties relating to CommScope products or services. CommScope is committed to the highest standards of business integrity and environmental sustainability with a number of CommScope's facilities across the globe certified in accordance with international standards, including ISO 9001, TL 9000, and ISO 14001.

Further information regarding CommScope's commitment can be found at [www.commscope.com/About-Us/Corporate-Responsibility-and-Sustainability](https://www.commscope.com/About-Us/Corporate-Responsibility-and-Sustainability).

BR-110736.3-EN (07/18)